

### Description

Utilising advanced DSP technology, the Portaflow 220 (PF220) is the latest portable flow measurement and recording system to be added to the Micronics range of equipment.

The PF220 can display instantaneous fluid flow rates or velocity, together with totalised values.

A variable current or pulse output, proportional to the detected flow rate, is also produced by the PF220 to enable it to interface with a range of external control devices such as those found in building management or site monitoring systems.

The PF220 is very much designed with 'ease of use' in mind. An interactive QuickStart menu, which simplifies system installation at any suitable location, together with minimal set-up requirements, means that the system can be installed and brought into service very quickly. Furthermore, the application parameters for a particular site can be saved to non-volatile memory and instantly recalled if a site is revisited for monitoring at a later time – further reducing the set-up time.

The flow sensors, or transducers, connected to the PF220 instrument are attached to the outside of the pipe being monitored and provide totally non-invasive flow measurement without disturbing the existing plant equipment or process operation.



#### Application benefits:

- Non-invasive installation – the process operation being monitored is in no way interrupted or otherwise affected by the use of this equipment
- Simple installation – there is no overhead for additional fittings, plant modification, or retro-fit expenditure
- Zero fluid contact – no contamination risks of the process fluid and possible exposure of the monitoring equipment to corrosive or toxic liquids

#### Industries:

- Water
- Building services
- Energy management
- Power generation
- Petrochemical
- Oil/Gas
- Food/drink
- Pharmaceuticals
- Power plants
- Manufacturing

#### Applications:

- HVAC & energy system audits
- Pump verification
- Metering
- Process control
- Chemical addition
- Hydraulic systems
- Fire systems
- Leak detection
- Boiler testing

#### Standard features:

- Light-weight, hand-held instrument with large, easy to read graphic display and switchable backlighting
- Flow range 0.1m/sec to 20m/sec bi-directional
- Useable with pipes ranging 13mm - 1000mm outside diameter (depending on model)
- Operator selectable language
- Simple to follow dual function keypad
- Simple 'Quick Start' set up procedure
- Continuous flow monitoring, with 'Totalised' option
- Variable Pulse output proportional to flowrate
- Variable 4-20mA, 0-20mA or 0-16mA output proportional to flowrate, with simple range calibration
- Rechargeable battery with up to 20hrs continuous battery operation depending on load
- Mains/battery operation with battery charge management
- Diagnostics

## Principles of Operation

When ultrasound is transmitted through a liquid the speed at which the sound travels is accelerated slightly when transmitted in the same direction as the liquid flow and decelerated slightly when transmitted against it. The difference in time taken by the sound to travel over the same distance but in opposite directions is therefore proportional to the flow velocity of the liquid and can be used to calculate the flow rate.

### Transit time technique

This technique is known as 'transit time' measurement and is the method used by the Portaflow 220 system to calculate the liquid flow rate. Once the flow velocity is known it is a simple matter for the PF220 to calculate the volumetric flow.

### Operating modes

The Portaflow sensors can be set to operate in one of four modes determined mainly by the pipe diameter and the transducer set in use. The diagram below illustrates these modes and shows the importance of applying the correct separation distance between the transducers to obtain the best possible signal.

In practice, the PF220 determines the operating mode and calculates the appropriate transducer separation distance in response to site application data entered by the user.

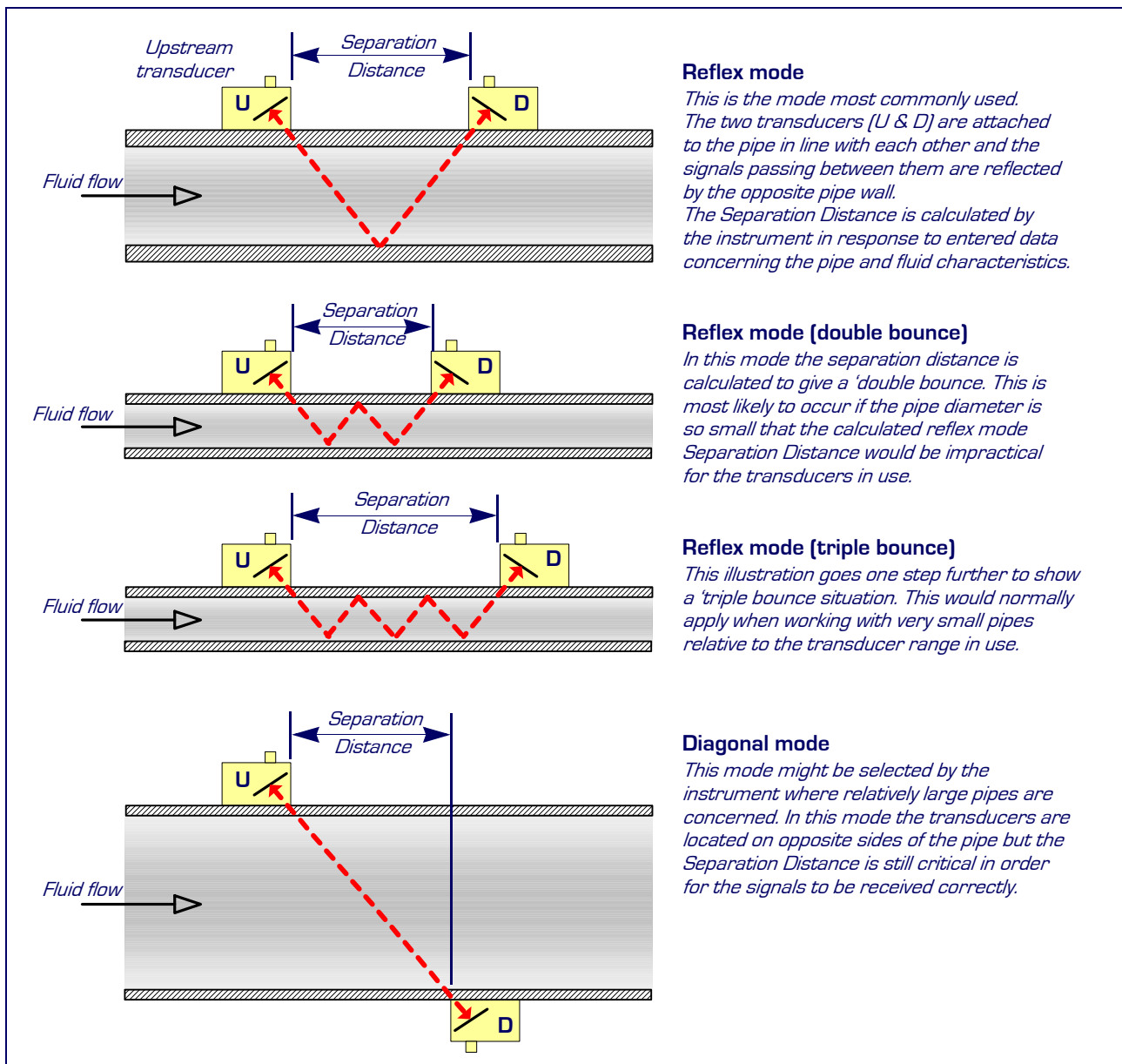

### Reflex mode

*This is the mode most commonly used. The two transducers (U & D) are attached to the pipe in line with each other and the signals passing between them are reflected by the opposite pipe wall. The Separation Distance is calculated by the instrument in response to entered data concerning the pipe and fluid characteristics.*

### Reflex mode (double bounce)

*In this mode the separation distance is calculated to give a 'double bounce. This is most likely to occur if the pipe diameter is so small that the calculated reflex mode Separation Distance would be impractical for the transducers in use.*

### Reflex mode (triple bounce)

*This illustration goes one step further to show a 'triple bounce' situation. This would normally apply when working with very small pipes relative to the transducer range in use.*

### Diagonal mode

*This mode might be selected by the instrument where relatively large pipes are concerned. In this mode the transducers are located on opposite sides of the pipe but the Separation Distance is still critical in order for the signals to be received correctly.*

**PF220 System components**

**Standard equipment**

- Portaflow 220 instrument with backlit graphic display
- Power supply - with UK, US, European adapters 110/240VAC
- Transducer cables (x2) 2 metres long
- Transducer set 'A' or 'B' [Depending on model]
- Set of guide rails for use with 'A' or 'B' transducers
- Ruled separation bar (2-piece)
- 4-20mA/Pulse output cable
- 2 lengths of chain (0.5m for PF220A and 3.3m for PF220B)
- Test block
- Ultrasonic couplant and syringe applicator
- Manual (on CD)



*The Portaflow 220 Standard equipment is supplied in a rugged polypropylene carrying case fitted with a foam insert to give added protection for transportation.*

### Application site specifications

When setting-up the PF220 using the QuickStart feature, specific data concerning the pipe construction and fluid conditions must be entered into the instrument in order for it to determine the appropriate transducer selection and fitting details. Once these parameters have been entered they can (optionally) be stored as a 'named site' in the Portaflow's memory and recalled if the equipment is used in the same site location in the future. This facility reduces the set-up time and is useful where the system is used at several site locations on a regular basis. Details for up to 20 sites can be stored in this manner.

The parameters that are required to be entered in the QuickStart menu are shown in the tables below, which also illustrate the range and limits of pipe and fluid conditions with which the system can be used.

#### Pipe material:

Constructed of any sonic conducting medium such as -

- Carbon Steel
- Stainless Steel
- Copper
- UPVC/PVDF
- Concrete
- Galvanised Steel
- Mild Steel
- Glass
- Brass

#### Pipe lining materials:

Permitted pipe linings include -

- Rubber
- Glass
- Concrete
- Epoxy
- Steel

#### Pipe wall thickness:

The pipe thickness must be in the range of 1mm - 75mm

#### Pipe lining thickness:

The pipe lining thickness can be up to 10mm

#### Pipe diameter:

The maximum permissible pipe outside diameter depends on the type of ultrasonic transducer in use -

- PF220A (type 'A' transducer) - usable with pipes in the range 13mm to 115mm
- PF220B (type 'B' transducer) - usable with pipes in the range 50mm to 1000mm

#### Fluid types & conditions:

The Portaflow 220 will perform accurately with a wide range of clean liquids or oils that have less than 3% by volume of particulate content. Typical application include -

- river water
- potable water
- demineralised water
- glycol/water mixture
- hydraulic oil
- diesel oil

#### Pipe wall temperature:

The maximum permissible pipe temperature is -20°C to +135°C

If the application parameters at the intended site fall outside those shown above contact Micronics for advice.

## Transducers

The PF220 system is supplied with one set of transducers with a temperature operating range of -20°C to +135°C. The PF220A is supplied with type 'A-ST' transducers and the PF220B is supplied with type 'B-ST'.

### PF220A standard transducers:

- 'A-ST' (2MHz) – used with 13mm 115mm pipe o.d.

### PF220B standard transducers:

- 'B-ST' (1MHz) – used with 50mm 1000mm pipe o.d.

## Transducer mounting

Type 'A' & 'B' transducers are fitted to adjustable guide rails which are secured to the pipe using wrap-around chains and mechanically connected together by a steel separation bar. The separation bar also acts as a ruler to allow the distance between the transducers to be set to the value calculated by the Portaflow instrument.

A thumb-wheel is used to adjust the chain tension until the assembly is held firmly in place. The transducers are then inserted into the guide rails and secured in place by a knurled screw. This illustration shows a completed assembly with a transducer fitted to the left-hand guide rail only.

The transducers are connected to the PF220 instrument by means of two 2m mini-coaxial cable.



## Control Outputs

The PF220 provides analogue and pulse outputs that are designed to be used in conjunction with external control and site monitoring applications such as those typically found in building management systems. These outputs can be calibrated to suit a required flow operating range and a high-flow alarm level.

Both outputs are connected to a single (green), 7-pin LEMO socket located on the top of the PF220 instrument. A single 2 metre cable is provided that can be adapted for use for either of these output functions. The 'tails' on the free end of the cable must be terminated to suit the intended application

### Cable termination

Red –	4-20mA positive
Black –	4-20mA negative
White –	Pulse output (+)
Green –	Pulse return (-)
Brown –	Set Point (not in present use)
Blue –	Set Point return (not in present use)
Thick Black –	Cable screen

### Analogue output:

Range –	4–20mA 0–20mA 0–16mA
Resolution –	0.1% of full scale
Alarm current –	Adjustable between 0–26mA
Isolation –	1500V Opto-isolated
Maximum load –	620 Ohms

### Pulse output:

Output type –	One open collector opto-isolated digital output
Pulse repetition –	Up to 500 pulses/sec (depending on pulse width)
Pulse width –	500ms for 1 pulse/s 5ms for 100 pulses/s
Max current –	150mA

## Technical data

### General specification:

DSP measurement technique -	The PF220 uses 'transit time' measurement with a sampling resolution of 50 picosecond, with a continuous signal level indication to the display									
Flow velocity range (bi-directional) -	<ul style="list-style-type: none"> <li>• Minimum velocity 0.1m/s</li> <li>• Max velocity 20m/s</li> </ul>									
Flow measurement accuracy -	<ul style="list-style-type: none"> <li>• ±0.5% to ±2% of flow reading for flow rate &gt;0.2m/s and Pipe ID &gt;75mm</li> <li>• ±3% of flow reading for flow rate &gt;0.2m/s and Pipe ID in range 13mm - 75mm</li> <li>• ±6% of flow reading for flow rate &lt; 0.2m/s</li> <li>• Flow velocity corrected for Reynolds number over entire velocity range</li> </ul>									
Repeatability -	• ±0.5% of measured value or ±0.02m/s whichever is the greater									
Response time -	• < 500ms depending on pipe diameter									
Selectable flow units -	<ul style="list-style-type: none"> <li>• VELOCITY: m/sec, ft/sec</li> <li>• VOLUME: l/s, l/min, l/h, gal/min, gal/h, USgals/min, USgals/h, Barrel/h, Barrel/day, m<sup>3</sup>/s, m<sup>3</sup>/min, m<sup>3</sup>/h</li> </ul>									
Selectable volume units -	• l, gal, USgals, Barrel, m <sup>3</sup>									
Total volume -	• 12 Digits - forward and reverse									
Display languages -	<p>The following operator languages can be selected from the PF220 set-up menu</p> <table border="0" style="width: 100%;"> <tr> <td>• English</td> <td>• Italian</td> <td>• Russian</td> </tr> <tr> <td>• French</td> <td>• Spanish</td> <td>• Norwegian</td> </tr> <tr> <td>• German</td> <td>• Portuguese</td> <td>• Dutch</td> </tr> </table>	• English	• Italian	• Russian	• French	• Spanish	• Norwegian	• German	• Portuguese	• Dutch
• English	• Italian	• Russian								
• French	• Spanish	• Norwegian								
• German	• Portuguese	• Dutch								

## Electrical

### Supply voltage:

Input voltage range -	9-24Vdc
Power consumption -	10.5W

### Battery:

Technology -	5-cell NiMH
Capacity -	3.8Ahr
Operating time -	Typically 20 hours continuous with backlight and 4-20mA output OFF
Recharge time -	6.5 Hours
Service life -	>500 charge/discharge cycles

### Power supply charger:

Manufacturer -	Model ECO-181WP12
Input voltage range -	90-264Vac
Input frequency range -	47-63Hz
Output voltage -	12Vdc
Max. Output current -	1.5A
Approvals -	UL, CUL, TUV, CB & CE

**Mechanical & miscellaneous data**

All components are contained in a hard-wearing polypropylene carrying case with a protective moulded foam insert.

Instrument enclosure:	
Material -	Flame retardant injection moulded ABS
Dimensions -	264mm x 168mm x 50mm
Weight -	1.1 kg (including battery)
Number of Keys -	16
Display -	240 x 64 pixel graphic display, high contrast black-on-white, with backlight
	Viewing angle: Min 30°, typically 40°

Shipping information:	
Box dimensions -	505mm x 125mm x 420mm
Weight -	6.0 kg
EMC -	BS EN 61326 - 1:2006, BS EN 61326-2-3:2006
Volumetric weight -	4.5 kg

Environmental:	
Operating temperature -	-20°C to +50°C
Storage temperature -	-25°C to +65°C
Operating humidity -	90% RH MAX at +50°C

Approvals:	
Safety -	BS EN 61010
Battery charger -	EN61204 - 3
EMC -	BS EN 61326 - 1:2006, BS EN 61326-2-3:2006

**Dimensions**

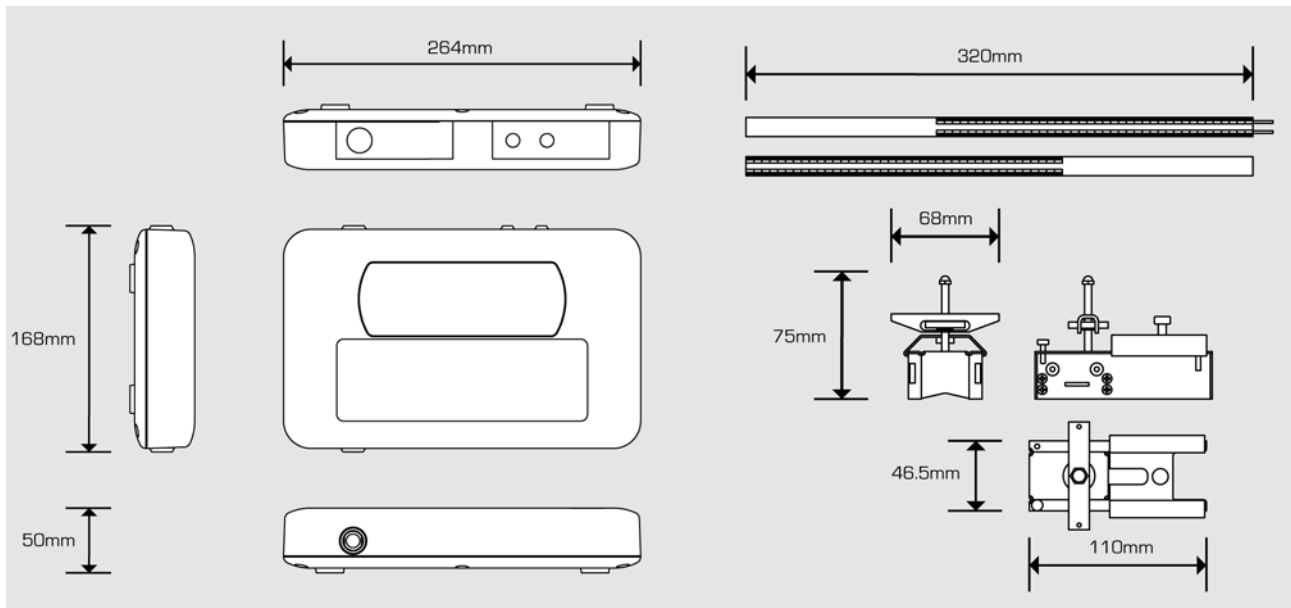

**Micronics reserve the right to alter any specification without notification.  
PORTAFLOW™ 220 and PF220 are identical.**



